

DALI-2 Touchpanel 8P DA2

Operating and control unit



Product description

- _ Capacitive DALI-2 Touchpanel with 8 freely programmable touch buttons
- _ Suitable for integration and in combination with DALI-2 compliant central control units (e.g.: Tridonic products sceneCOM evo and sceneCOM S)
- _ Multi-master compatible: Multiple control modules are possible in a DALI system
- _ Power supply via DALI line
- _ Two colour variants available: black (28004783) and white (28004782)
- _ 5 years guarantee (conditions at <https://www.tridonic.com/en/int/services/manufacturer-guarantee-conditions>)

DALI Touchpanel 8P DA2 WH



DALI Touchpanel 8P DA2 WH



DALI Touchpanel 8P DA2 BK

Website

<http://www.tridonic.com/28004782>



DALI-2 Touchpanel 8P DA2

Operating and control unit

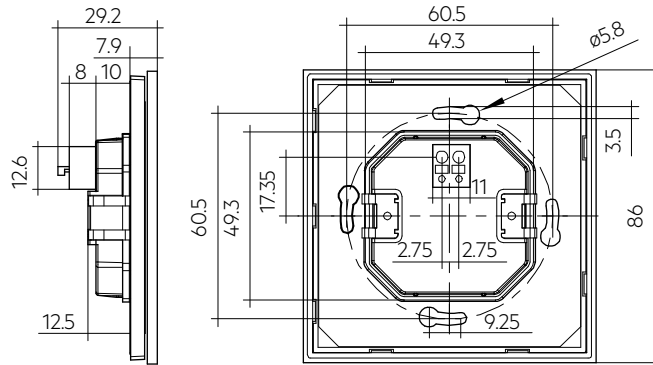
**Ordering data**

Type	Article number	Packaging, carton	Weight per pc.
Touchpanel 8P DA2 WH	28004782	36 pc(s).	0.12 kg
Touchpanel 8P DA2 BK	28004783	36 pc(s).	0.12 kg

Technical data

Supply via	DALI cable
Supply voltage ^①	9,5 – 22,5 V
Current draw ^②	2 mA
Interface	DALI
Starting time	< 150 ms
Ambient temperature t _a	-20 ... +50 °C
Max. casing temperature t _c	60 °C
Storage temperature t _s	-20 ... +50 °C
Humidity	5 ... max. 85 % (non-condensing)
Type of protection	IP20
Housing material	PC
Housing colour	RAL 9010 (weiß) / RAL 9005 (schwarz)
Mounting	Mounting box 60 x 40 mm (ø x d)
Dimensions L x W x H	86 x 86 x 29,2 mm
Guarantee (conditions at www.tridonic.com)	5 Year(s)

Approval marks**Standards**

EN 55015, EN 61347-1, EN 61347-2-11, EN 61547, EN 62386-101, EN 62386-103, EN 62386-301

① U_{in} acc. IEC 62386-101.

② Max. current draw is 10 mA.

1. Standards

- EN 55015
- EN 61347-1
- EN 61347-2-11
- EN 61547
- EN 62386-101 Ed.2.0
- EN 62386-103 Ed.2.0
- EN 62386-301 Ed.2.0

1.1 DALI note



Device is developed according to DALI Standard EN 62386-101 Ed.2, also known as DALI-2.

To be able to use the device in such installation, an application controller is necessary.

Following table shows the instances and which values they provide.

DALI instances	
Instance number ^①	Explanation
0 – 7	Push button DALI Part 301

① The order of the instances is visible in the wiring diagram.

Behind every instance 2 feedback LED's are located. The LEDs can be switched on or off if the Application controller supports this feature.

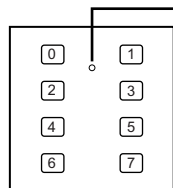

In addition a feedback LED is build in in the top middle. This LED lights up red briefly when a button is pressed. So the user gets an optical feedback every time he pushes a button.

1.2 Glow wire test

according to EN 61347-2-11 passed for temperatures up to 850°C.

2. Installation / wiring

2.1 Wiring diagram

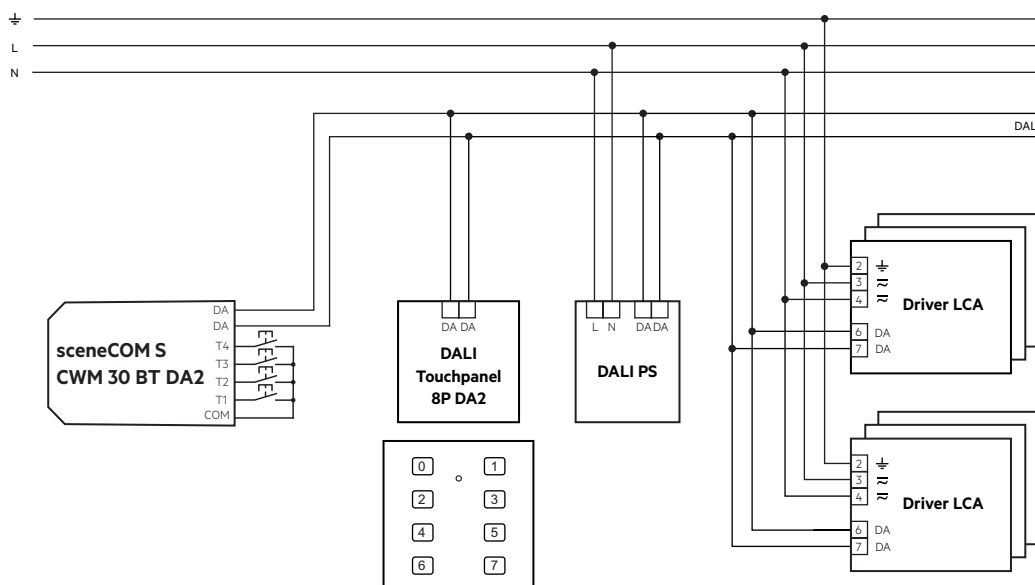

2.2 Wiring type and cross section

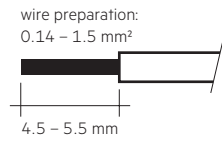

For wiring use stranded wire with ferrules or solid wire from 0.14 to 1.5 mm².

2.3 Safety instructions:

- **DALI is not SELV.** Apply the installation instructions for mains voltage.
- Installation: fixed only, in a clean and dry environment.
- Supply: via DALI control line only; no mains voltage allowed.
- DALI control line: use standard installation material for low-voltage systems (< 1000 V); only tree, linear and star topologies permitted; cores may be reverse connected.
- Terminals D1/D2: do not connect with mains line.
- Terminals: when using solid conductors, connect only one per terminal.
- Handle with care, the glass may be damaged if dropped, burned, punctured or crushed.
- Static electricity, sweat, oil and other impurities on your hand or on the touch panel may result in a not responsive touchscreen. If this happens please make sure to clean the touch panel and your hands.
- The device may only be used for the application area specified.
- Relevant health and safety regulations must be observed.
- While assembling and installing the device, the voltage supply must be disconnected.
- Only qualified personnel may assemble, install and commission the device.
- If an error occurs, dangerous voltage levels may be present at the DALI terminals and on the DALI control line.



There is a risk of electric shock when touching these terminals in case of failure.

Note: In some countries basic insulated control terminals are to be marked with this symbol.

2.4 Installation:

Push button function label can be printed and customized, to better indicate whatever functions configured to the push buttons.
Following illustration visualizes the installation:

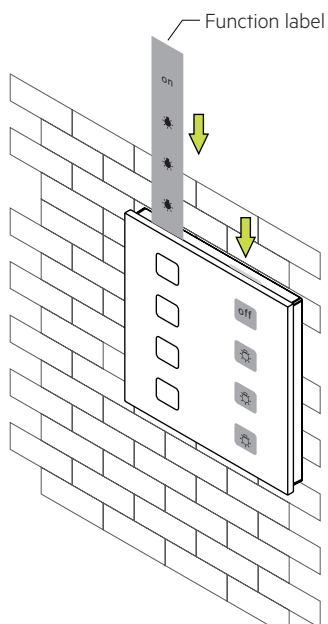
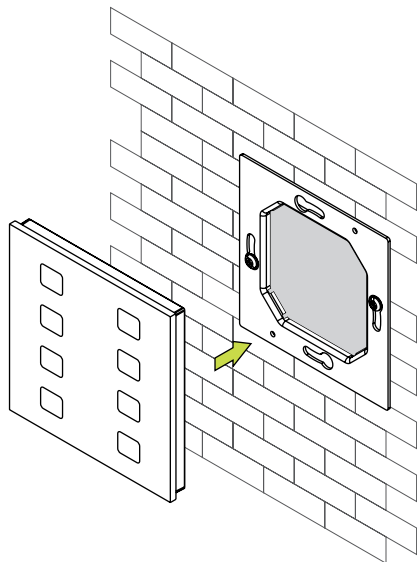
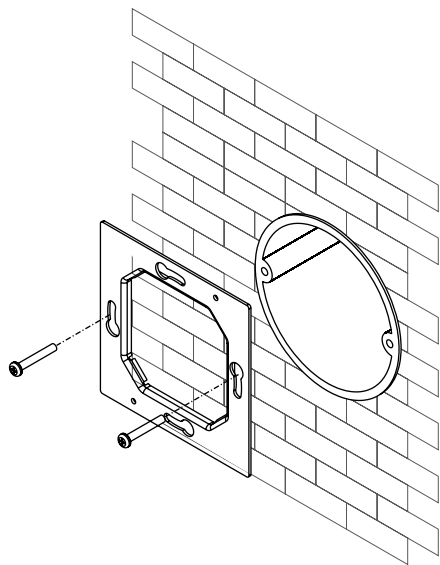

Examples labels:

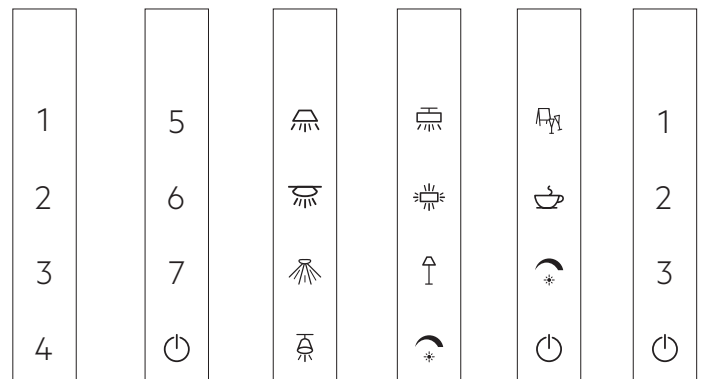

3. Miscellaneous

3.1 Disposal



According to the WEEE directive return old equipment at appropriate collection facilities.

3.2 Additional information

Additional technical information at www.tridonic.com → Technical Data

Guarantee conditions at www.tridonic.com → Services

Lifetime declarations are informative and represent no warranty claim.
No warranty if device was opened.